

Induction Motor

90 Watt

Square Flange
90mm x 90mm

Continuous Duty
Clockwise or Counter Clockwise Rotation
Terminal Box or Lead Wires For Connection
Totally Enclosed Fan Cooled Aluminium Body

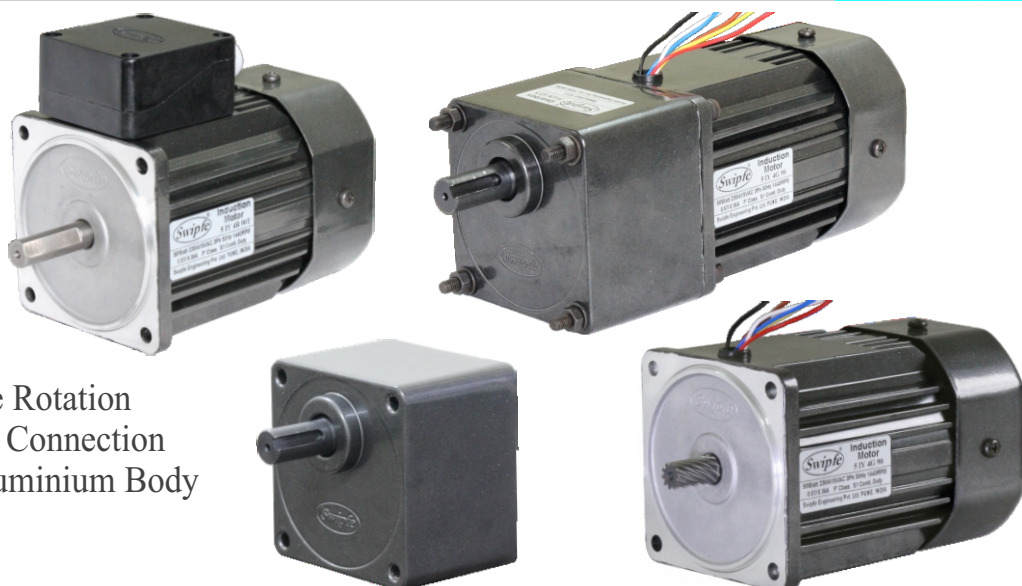

Specifications:

Model	Supply	Freq.	Stall Torque Nm	Rated Torque Nm	Rated Speed RPM	Rated Current Amp	Cap. µF
5IX4□90	Single Phase 230V	50	0.86	0.67	1300	0.54	4
5IY4□90	Three Phase 230V	50	0.86	0.73	1250	0.44	-
5IY4□90	Three Phase 415V	50	1.10	0.61	1350	0.25	-
5IX2□90	Single Phase 230V	50	0.45	0.34	2700	0.46	2.5
5IY2□90	Three Phase 230V	50	0.39	0.33	2600	0.47	-
5IY2□90	Three Phase 415V	50	0.56	0.34	2700	0.26	-

□ Indicates type of Shaft, G - Gear, R - Round, F - Frame, C - Custom

Gearmotor Torque Table:

The maximum permissible torque is 20 Nm

No Load speed of Motor at 50Hz is approx. 1440RPM

50Hz

Unit : Nm

RPM	480	400	288	240	192	160	115	96	80	57	48	40	29	24	19	16	14	12	9.6	8
Gear Ratio	3	3.6	5	6	7.5	9	12.5	15	18	25	30	36	50	60	75	90	100	120	150	180
Output Torque	1.7	2.0	2.8	3.3	4.2	5.0	6.3	7.5	9.1	11.2	13.4	16.1	20.0	20.0	20.0	20.0	20.0	20.0	20.0	20.0

The Gear boxes are sold separately.

A coloured background indicates gear shaft rotation in same direction as motor shaft.

A white background indicates gear shaft rotation in opposite direction to the motor shaft.

The speed of geared motor is calculated by dividing motor's no load speed by the gear ratio.

The actual speed is less than the displayed value, depending upon the load.

Characteristics, specifications and dimensions are subject to change without notice.

Dimensions:

Motor, Gearbox with Terminal Box

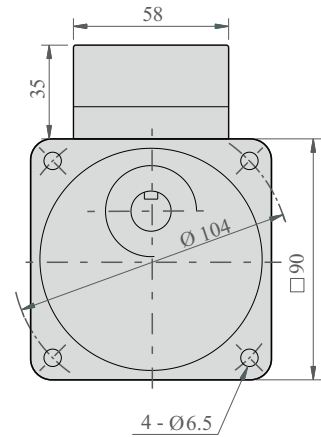
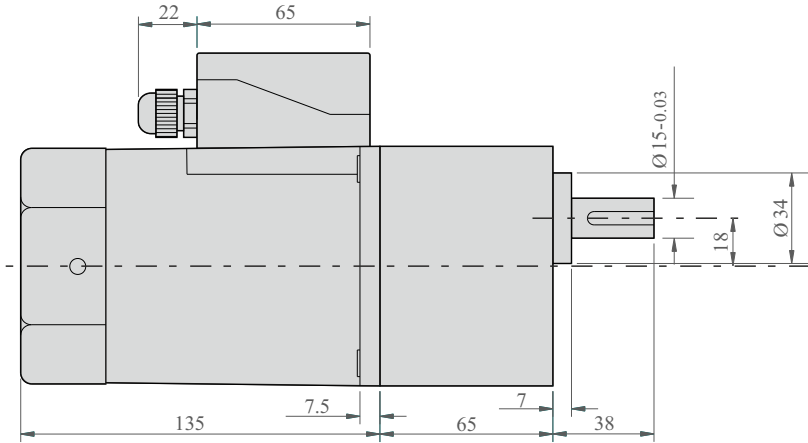

Motor Round Shaft with Terminal Box

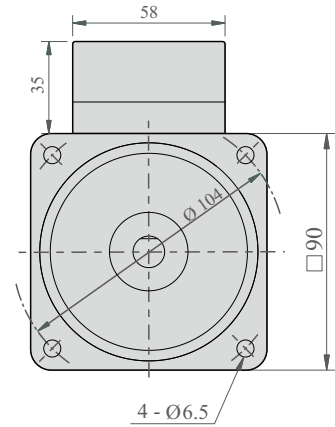
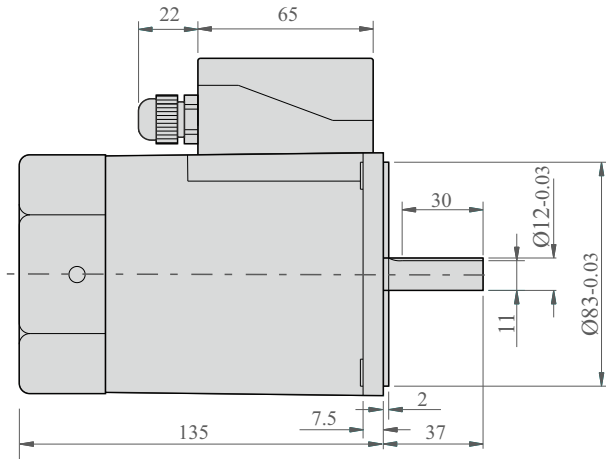

Motor, Gearbox with Lead Wires

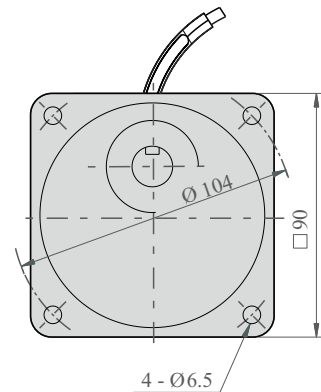
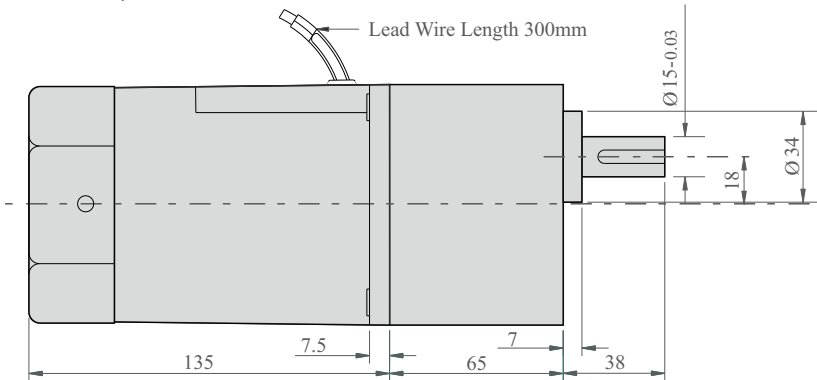

Key & Keyway

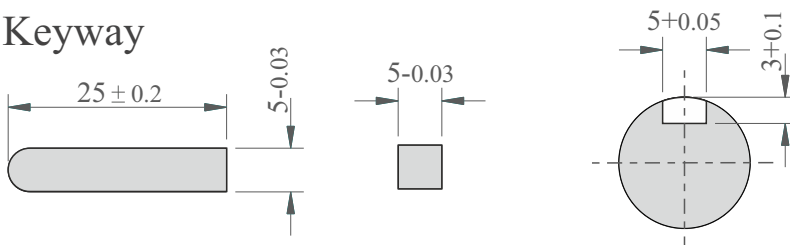

Max. Weight:
 Motor - 2.7 kg
 Gear Box - 1.7 kg

Induction Motor

Wiring Diagrams:

Wiring Diagram for Single Phase Motor

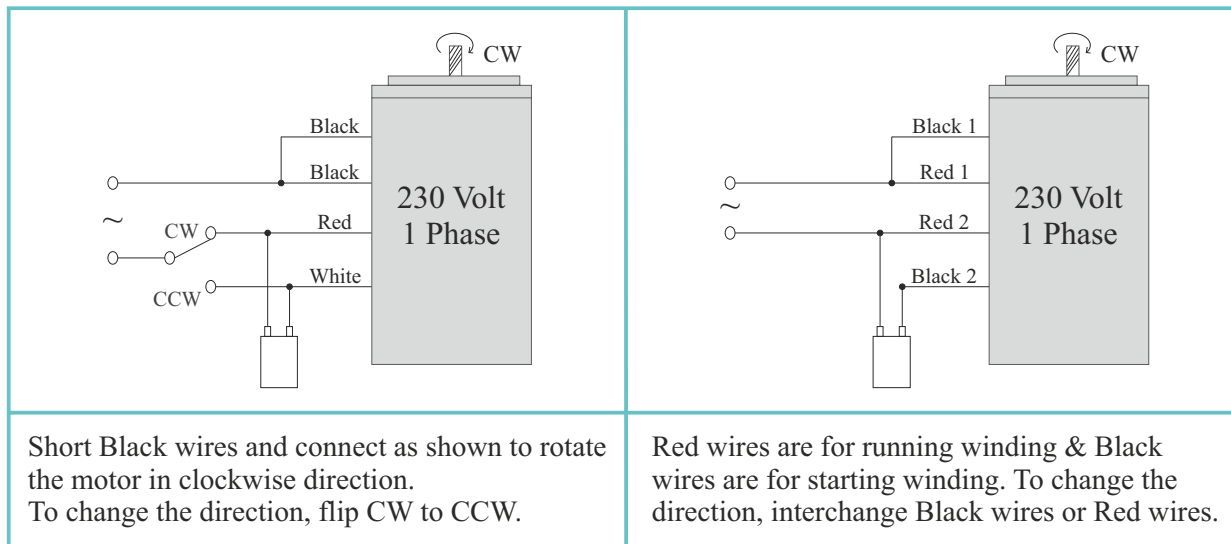

Wiring Diagram for Three Phase Motor

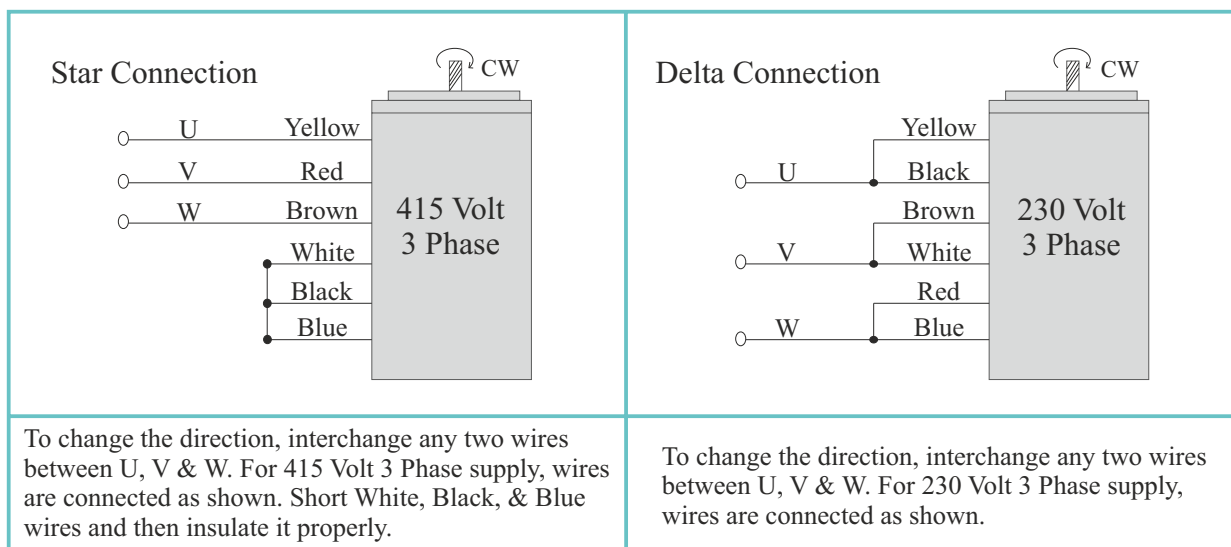

Change the direction of motor only after it stops rotating. If the attempt is made during rotation, motor may not change the direction or change the direction after some time.